

nScan-Ken 1vo
for Scan-Speak 10F

07-november-2015 | designed & drawn by dld
© 2007-15 planet_10 enterprises limited
free for non-commercial use

Notes:

- 0/ All panels 12mm, high quality multi-ply recommended
- 1/ Don't forget to angle cut the back of the driver cut-out to give it breathing room
- 2/ All internal panels lined with ~1/2" (12mm) wool or cotton felt. Note that it is hard to get into the box after it is sealed up

half-sheet

2 vent spacers from 9mm material.
 Preferably a different material from the box

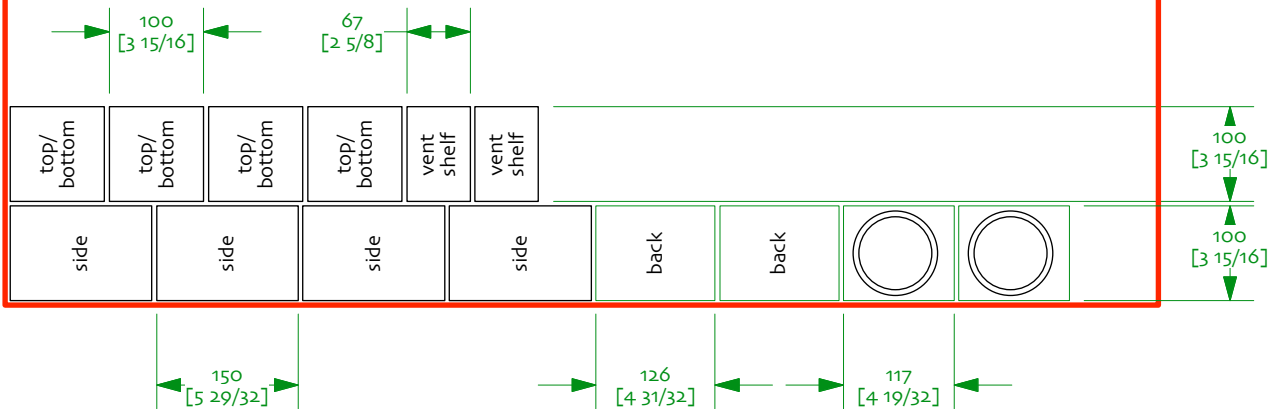
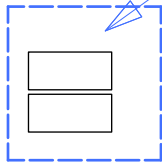

nScan-Ken 1vo
 suggested cut-plan (12mm 4x8)
 07-november-2015 | designed & drawn by dld
 © 2007-15 planet_10 enterprises limited
 free for non-commercial use

Notes:
 o/ 12mm material, quality plywood recommended
 1/ 5mm kerf & trim allowance

